

Installation Instructions

Geissele Super Modular Rail, MK14 Magpul M-LOK Rails

The Geissele Super Modular Rail (SMR) MK14 Magpul M-LOK is easy to install. However, it will need some specialized tools that you may not have. Installation by a certified gunsmith is recommended. In the following installation instructions refer to Geissele drawing MK14 for the positioning of the rail components. *Please note that the MK14 series does **NOT** include accessory rails.*

The SMR is designed to fit M4 Carbine mil-spec flat top upper receivers and must be used with a low profile gas block such as the Geissele Super Gas Block (SGB). Upper receivers that are not mil spec such as those manufactured from billet may need to have gunsmith modifications made to the SMR to fit properly. Compatibility with gas piston systems is unknown at this time.

- 1) Remove existing flash hider, handguard and front sight/gas block/gas tube.
- 2) Use the supplied Geissele barrel nut wrench (Item 3) to remove the stock barrel nut and discard.
- 3) Remove barrel and inspect and clean the upper receiver threads. Reinstall the barrel being careful to align the barrel extension indexing pin with its corresponding slot in the upper receiver threads.
- 4) Liberally coat the upper receiver threads and the outer face (torque shoulder) of the barrel extension with anti-seize or grease. If these are not available, oil or CLP may be substituted.
- 5) Slide the aircraft aluminum Geissele barrel nut (Item 2) over the barrel and hand tighten.
- 6) Use the Geissele barrel nut wrench to tighten the Geissele barrel nut to 40 ft-lbs by using the pin and corresponding hole in the OD of the barrel nut. Torquing of the barrel nut is recommended.

However, for the last 40 years the stock barrel nut has not been torqued, only indexed to line up with the gas tube. If you are an experienced AR builder and are sure of your ability to properly tighten the stock barrel nut you can alternately tighten the Geissele barrel nut with a ratchet or breaker bar in the ½" square aperture in the Geissele wrench.

- 7) Install the gas block and gas tube being careful to line up the gas tube with the center of the gas tube hole in the upper receiver. Once installed take the bolt carrier assembly and slide into the upper receiver making sure the gas tube slides freely onto the gas key and there is no binding.
- 8) Slide the SMR handguard (Item 1) onto the barrel nut. Be very careful when doing this as the clearance between the OD of the barrel nut and ID of the handguard is precisely machined to about 0.001" clearance. Burrs or dings on the barrel nut will not allow the handguard to slide freely. It is recommended to lightly coat the barrel nut OD and ID of the handguard with a light film of oil before installing until you get the hang of installation. Slide the handguard against the barrel nut, then use your fingers to align the other end of the handguard concentric to the barrel so the rail section is not cocked. By wiggling the handguard very slightly and pressing downward

it will start on the barrel nut. Once it is about ½” onto the barrel nut it can be slid home. Do not force the handguard onto the barrel nut. If force is needed there is something wrong. Remove the handguard and inspect the OD and ID interface.

- 9) Install the two rail mounting bolts and washers (Items 4 and 5). You may have to slide the handguard slightly to line up the holes with the grooves in the barrel nut in order for the bolts to start. Start the bolt threads into the dogbone nut (Item 6). Do not tighten the rail mounting bolts fully at this time.
- 10) Time the top M1913 rail to the M1913 rail on top of the upper receiver. We recommend this is done by bridging the two rails with a scope mount and tightening up the mount so that the rails are rotationally aligned.
- 11) Tighten the two rail mounting bolts to 5.0 ft-lbf. Keep the scope mount installed during the tightening process. If a torque wrench is not available use a short arm allen key (Item 9) and tighten snug.
- 12) Tighten the two rounded point set screws (Item 7) against the upper receiver using the 5/64” Allen Key (Item 8).
These two screws are just a secondary method of ensuring the rail section does not rotate. The clamping of the rail onto the barrel nut is very secure and will not rotate even under abuse. Just a light torque on the screws is all that is needed for a bomb proof anti-rotation feature.
- 13) Note: the 9 and 3 o'clock M1913 rail sections toward the muzzle are designed with a very low profile.
Some accessories that have excessive overhang from the tapered sections of the M1913 profile may not fit without accessory modification at these locations.
- 14) Be sure to check and retighten the rail mounting bolts after the first firing of the weapon. The dogbone nut has two small barbs that bite into the rail to keep the dogbone nut captured and prevent it from falling out when the mounting bolts are removed. It takes a little time for the barbs to fully seat into the rail; one or two re-tightenings of the mounting bolts are all that is needed to fully seat the dogbone nut.
- 15) ATTENTION: Do not tighten the cross bolts when the rail is not installed on a barrel nut . Tightening the bolts with the rail un-installed will crush the ID to the point where the rail is unusable. Tightening the cross bolts to more than 5 ft-lbs will also damage the rail. If a torque wrench is not available just use the provided short arm allen key (not a long arm allen key and do not put a cheater bar on the short arm allen key). By using a short arm key a normal man that tightens the bolts snug and tight will not exceed 5 ft.lbs.
- 16) Installation is now complete. If any questions arise during installation please email sales@geissele.com or call the shop at (610) 272-2060 to speak to a technician.

UTILIZING THE M-LOK ATTACHMENT SYSTEM

The MK14 M-LOK has been designed using Magpul's advanced M-LOK modular locking accessory mounting system. This system allows the user to easily add or remove accessories based on mission requirements using a 1/8" hex key. Be sure to read the instructions below carefully, improper installation may cause permanent damage to your rail that is not covered by the Geissele warranty.

1. To install make sure the nut is started onto the bolt with at least 1 full thread showing out the back of the nut (Figure 1.). If one full thread is not showing, there is a chance that the M-LOK nut will not cam into the M-LOK slot properly. If this occurs and the screw is tightened, the M-LOK nut can pull through the rail leaving a gash in the rail and causing a burr in the surface.

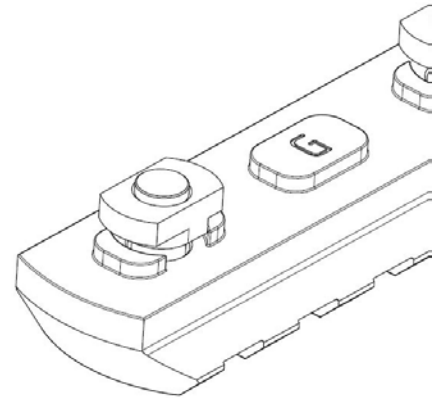

Figure 1 M-Lok with one full thread showing.

2. Align the nut with the recoil lugs so they pass through the M-LOK slots. (Figure 2.)

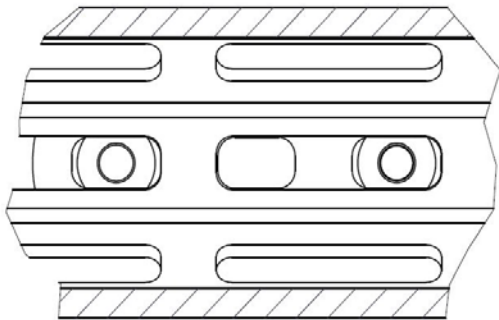

Figure 2 M-Lok lugs shown in the unlocked position

3. Begin to tighten the bolt one full turn with the hex key. The cammed nut will rotate, tighten, and eventually lock into place retaining the accessory on the handguard. Additional torque can be applied to hold the accessory in place. (Figure 3.)

Removing the accessory requires 1 turn counterclockwise. The cammed nut will align with the recoil lugs on the accessory allowing the accessory to come off the rail. Care should be taken to not remove the nut from the bolt or M-LOK accessory. Loosening the screw further than 1 turn may result in permanent damage to the rail due to the issues described in Step 1.

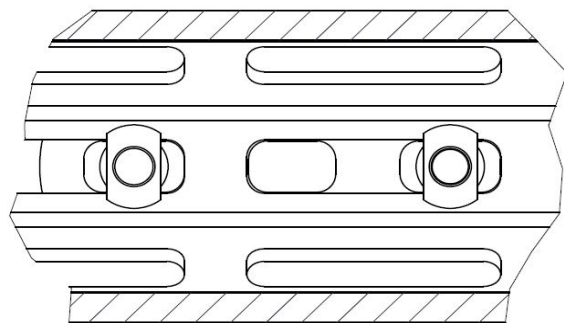
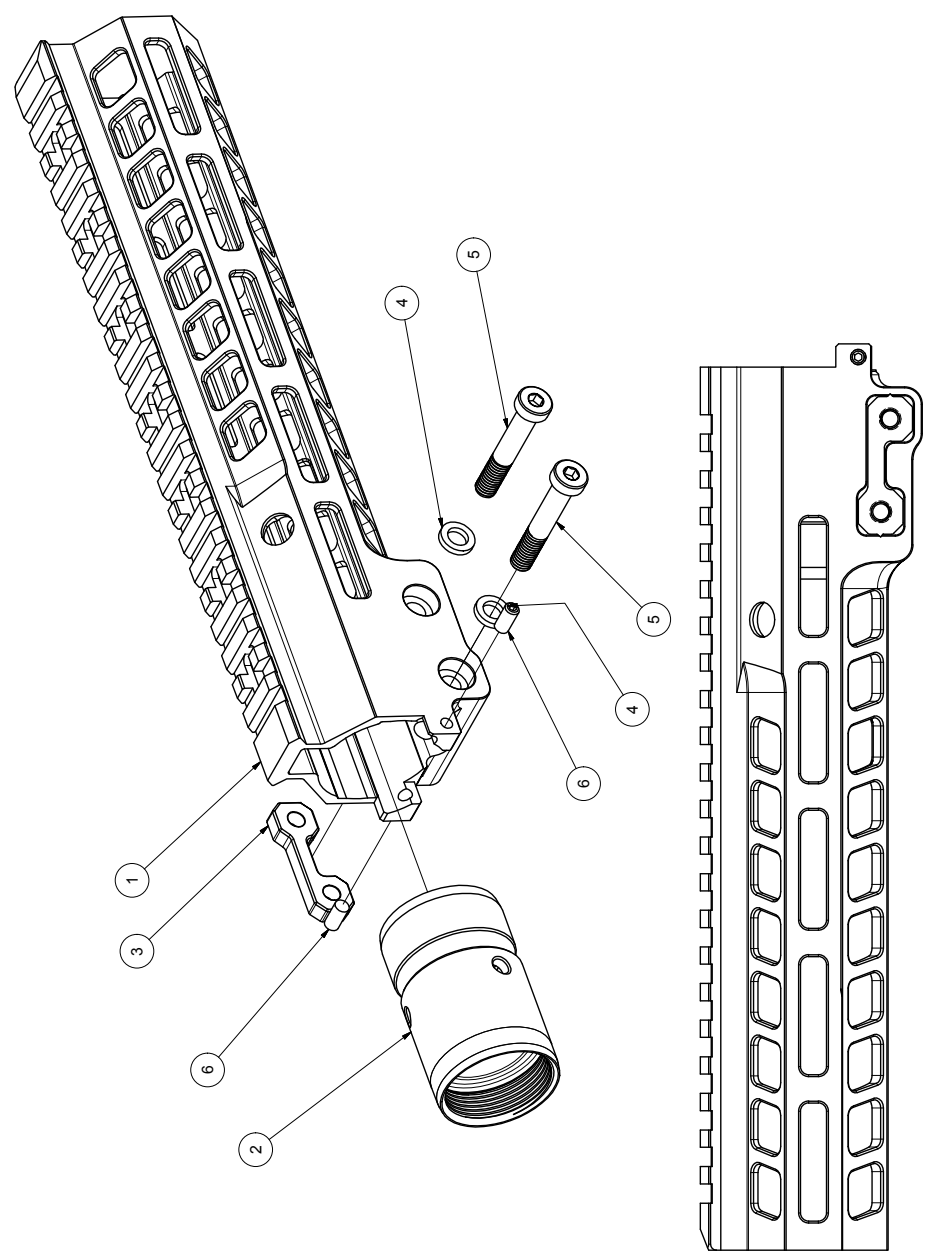

Figure 3 M-Lok lugs shown in the locked position

REVISION HISTORY		ZONE	REV	DESCRIPTION	DATE	APPROVED
		A		INITIAL RELEASE	5/30/2017	WHG

ITEM	QTY	PART NUMBER	DESCRIPTION
1	1	02-914	HANDGUARD, MARK 14 X 9.5 INCH
2	1	02-502	BARREL NUT SINGLE GROOVE
3	1	02-810	PRESS NUT MK13
4	2	02-323	WASHER M6 SCREW X 10mm OD X 1.8mm THK.
5	2	06-180	SCREW M6 X 1 X 1.445 LG. LOW SOCKET HEAD CAP. STEEL
6	2	06-133	SHSS #8-32 X 3/8" BLK. OX. OVAL POINT



GEISSELE AUTOMATICS LLC 800 NORTH WALES ROAD, NORTH WALES, PA 19454		HANDGUARD MK14 X 9-1/2"
ORIGINAL DATE OF DRAWING 5/30/2017	DRAFTSMAN WJQ	DWG NO 05-578
UNLESS OTHERWISE SPECIFIED DIMENSIONS ARE IN INCHES	ENGINEER WHG	REV A
TOLERANCES ON ANGLES: 0.3 DECIMALS: 0.x .020 0.xx .010 0.xxx .005	APPROVED WHG	DWG SIZE C
FRACTIONS: 1/32	UNIT VOLUME NONE	SCALE 1 OF 1
MATERIAL NONE	HEAT TREATMENT NONE	SHEET
FINISH NONE	FINAL PROTECTIVE FINISH NONE	UNIT WEIGHT

THIS DRAWING IS PROPRIETARY AND CONFIDENTIAL

THIS DRAWING HAS COPYRIGHT WHICH IS OWNED BY GEISSELE AUTOMATICS. NEITHER THIS DRAWING NOR THE INFORMATION ILLUSTRATED THEREIN IS TO BE REPRODUCED, COPIED, OR TRANSMITTED IN ANY FORM OR BY ANY MEANS, WITHOUT WRITTEN AUTHORITY FROM GEISSELE AUTOMATICS. THIS DRAWING HAS BEEN DELIVERED ON THE UNDERSTANDING THAT IT IS NOT TO BE USED IN ANY WAY AGAINST THE INTERESTS OF GEISSELE AUTOMATICS AND WILL BE RETURNED ON DEMAND.